



# Serial/Parallel Modem with Discrete DAA and Speakerphone Support

CX06833

## Controller-Based Modem for Embedded Applications

Conexant's broadband communications portfolio includes a comprehensive suite of semiconductor solutions that enable the digital home and information network. Dial-up modems continue to be the predominant method of communication for the embedded market.

The CX06833 modem is ideal for country-specific embedded applications such as POS Terminals, Set-top Boxes, Metering, Building Automation, Gaming, Ruggedized Notebooks, Remote Site Management and any other application that requires a robust dial-up modem solution.

The device integrates the microcontroller, digital signal processor, memory and support for a discrete DAA. The CX06833 supports either serial or parallel host interface operation and it is available in a 144-pin TQFP package.

The CX06833 modem features data/fax/Telephone Answering Machine (TAM) and optional full-duplex speakerphone with up to 56 kbps analog data modem operation and 14.4 kbps fax modem operation. The V.92 modem includes Quick Connect, Modem-on-Hold™ and PCM Upstream. The CX06833 is also available in V.34 or V.32bis options.

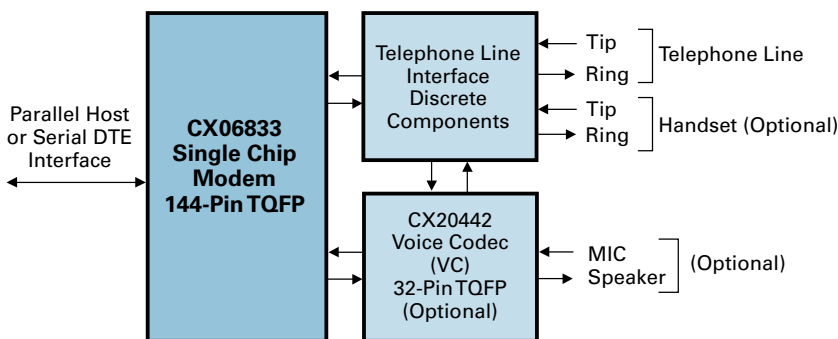

**CX06833 Modem Major Interfaces**



## Distinguishing Features

- **Modulations**
  - ITU-T V.92, V.90 (SM56D models)
  - ITU-T V.34 (SM56D/SM336D)
  - ITU-T V.32bis, V.32, V.22bis, V.22 fast connect, V.23 and V.21
  - Bell 212A and Bell 103
  - V.250 and V.251 commands
  - V.80 synchronous access mode
- **V.92, V.34 and V.32bis options**
  - V.92 includes Modem-on-Hold™, Quick Connect and PCM Upstream
- **FastPOS (V.29) and V.22 fast connect**
- **TAM and optional full-duplex speakerphone**
- **V.44/V.42bis and MNP5 data compression**
- **V.42 and MNP2-4 error correction**
- **144-pin TQFP package**
- **Fax modem send and receive rates up to 14.4 kbps**
- **Quick time-to-market**
- **Low-cost solution**
- **Optional Pb-free devices available**

<b>Part Number</b>	CX06833
<b>Description</b>	Serial/Parallel Modem with Discrete DAA and Speakerphone support



## CX06833 Features

- **Data modem**
  - ITU-T V.92, V.90 (SM56D models), V.34 (SM56D and SM336D models), V.32bis, V.32, V.22bis, V.22, V.23, and V.21; Bell 212A and Bell 103
  - Quick Connect, Modem-on-Hold™ and PCM Upstream functions (SM56D models)
  - V.250 and V.251 commands
- **Data compression and error correction**
  - V.44 data compression
  - V.42bis and MNP 5 data compression
  - V.42 LAPM and MNP 2-4 error correction
- **Fax modem send and receive rates up to 14.4 kbps**
  - V.17, V.29, V.27 ter, and V.21 channel 2
  - EIA/TIA 578 Class 1 and T.31 Class 1.0
  - FastPOS (V.29) and V.22 fast connect
- **V.80 synchronous access mode supports host-controlled communication protocols with H.324 interface support**
- **Interfaces to optional external ROM/flash ROM, RAM, and/or serial EEPROM**
  - Supports custom firmware
- **Data/Fax/Voice call discrimination**
- **Support for many country-specific DAA configurations**
  - Caller ID detection for many countries
  - Call progress, blacklisting
  - Internal ROM includes default values for 29 countries
  - Additional modified country profiles can be stored in internal SRAM or optional serial EEPROM
- **Caller ID detect**
  - On-hook Caller ID detection
  - Off-hook Call Waiting Caller ID detection during data mode in V.92, V.90, V.34, V.32bis, and V.32
- **Distinctive ring detect**
- **Modem customization available through patch code that can be stored in optional serial EEPROM or internal SRAM**
- **Telephony/TAM**
  - V.253 commands
  - 2-bit and 4-bit Conexant ADPCM, 8-bit linear PCM, and 4-bit IMA coding
  - 8 kHz sample rate
  - Concurrent DTMF, ring, and Caller ID detection
- **Full-duplex speakerphone (FDSP) mode using optional CX20442 Voice Codec (S models)**
  - Microphone and speaker interface
  - Telephone handset or headset interface
  - Acoustic and line echo cancellation
  - Microphone gain and muting
  - Speaker volume control and muting
- **Built-in host/DTE interface**
  - Parallel 16550A UART-compatible interface up to 230.4 kbps
  - Serial ITU-T V.24 (EIA/TIA-232-E) logical interface up to 115.2 kbps
- **Direct mode (serial DTE interface)**
- **Flow control and speed buffering**
- **Automatic format/speed sensing**
- **Serial async/sync data; parallel async data**
- **Thin packages support low profile designs (1.6 mm max. height)**
  - CX06833: 144-pin TQFP
  - CX20442 VC: 32-pin TQFP
- **+3.3V operation with +5V tolerant digital inputs**
- **Typical power use**
  - CX06833: 161 mW (Normal Mode); 52.8 mW (Sleep Mode)
  - CX20442 VC: 5 mW (Normal Mode)

## Conexant Product Portfolio

The company's broad portfolio of semiconductor products also includes client-side DSL, cable, and dial-up modem solutions; fiber optic system-on-chips; broadcast video encoders and decoders; digital set-top box components and systems solutions; and IEEE 802.11a/b/g/n-compliant WLAN chipsets. Additional products include a complete line of asymmetric and symmetric DSL central office solutions, which are used by service providers worldwide to deliver broadband data, voice, and video over copper telephone lines.

© 2002, Conexant Systems, Inc. All Rights Reserved. Conexant and the Conexant logo are trademarks of Conexant Systems, Inc. All other trademarks are owned by their respective owners. Although Conexant strives for accuracy in all its publications, this material may contain errors or omissions and is subject to change without notice. **THIS MATERIAL IS PROVIDED AS IS AND WITHOUT ANY EXPRESS OR IMPLIED WARRANTIES, INCLUDING MERCHANTABILITY, FITNESS FOR A PARTICULAR PURPOSE AND NON-INFRINGEMENT.** Conexant shall not be liable for any special, indirect, incidental or consequential damages as a result of its use.

**www.conexant.com**  
General Information:  
U.S. and Canada: (800) 854-8099  
International: (949) 483-6996  
Headquarters – Newport Beach  
4311 Jamboree Rd, P.O. Box C  
Newport Beach, CA 92660-3095

Doc# PBR-200236

